

# HLP3000DS



The 3000DS model has three 1 KW Glare Control lamps, fitted into three individual cassettes.

Unit is equipped with an ultrasonic distance indicator allowing it to be correctly positioned.

Lamps emit short wave infrared heat ideal for optimizing drying of waterborne paints.

This flexible system allows each cassette to be adjusted and locked into position around the contours of the vehicle body, ensuring maximum area coverage.

Height adjustment is made using the high performance locking gas strut, offering a near weightless movement to the cassette support arm.

Typical drying cycle only costs 9 Pence (Based on 1Kw/hour of electricity costing 12 pence)

## Product features include

- 500mm 1Kw High output GC short wave lamps fitted to each cassette.
- Twin 30 minute timers on both the Flash and Bake settings.
- Power settable on both Flash and Bake Cycle.
- Distance indicator with safety cut out if unit is moved too close.
- Robust steel constructed stable frame, fitted with rear wheel locking castors.
- Maintenance free cassettes with no fan or filter changes.
- Individually switched cassettes.
- Horizontal or vertical cassette operation.
- Long lamp/emitter life with an average of 6000hours. Typically 4 – 5 years continuous professional use.

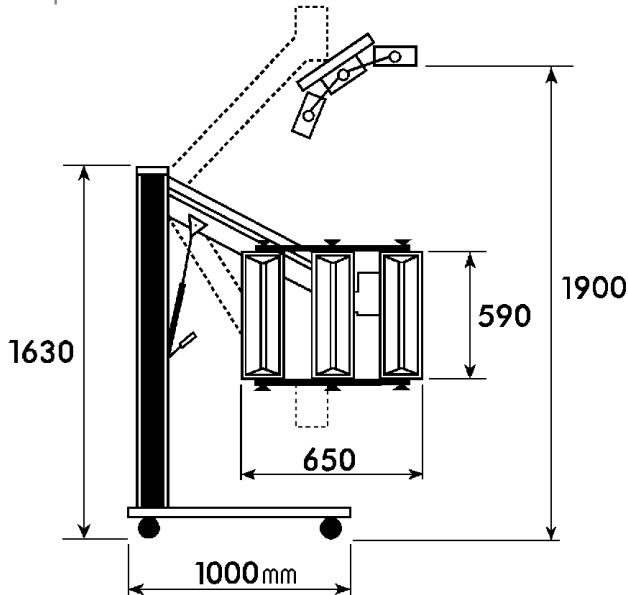

**Area coverage:-** 800mm x 1000mm  
 Minimum operating distance:- 500mm  
 Max vertical curing height:- 2030mm  
 Max horizontal curing height:- 1800mm

### Average curing specification

Filler / Stopper:- 4 – 6 minutes  
 Primer:- 6 – 8 minutes  
 Top coat:- 10 – 12 minutes

### Electrical specification

220/240 Volt 3KW 50Hz single phase 12.50amps  
 380/415 Volt 3KW 50Hz 3 phase 4.25amps / phase

## La Grand E.V.O

Opzoomerstraat 21 b  
 3023 SE Rotterdam  
 tel. 010-2449966  
 lagrand-evo@planet.nl  
 www.lagrand-evo.nl



Distributed by