

# HLP4000DSTS



The 4000DSTS model has four 1 KW Glare Control lamps, fitted into four individual cassettes. Temperature is controlled through an optical electronic digital feedback loop which turns the heat up and down as required during the cycle.

The unit is equipped with a digital distance readout allowing it to be correctly positioned.

Lamps emit short wave infrared heat ideal for optimizing drying of waterborne paints.

This flexible system allows the cassettes to be adjusted and locked into position around the contours of the vehicle body, ensuring maximum area coverage.

Height adjustment is made using the high performance locking gas strut, offering a near weightless movement to the cassette support arm.

Typical drying cycle only costs 12 Pence (Based on 1Kw/hour of electricity costing 12 pence)

## Product features include

- 500mm 1Kw High output Glare Control short wave lamps fitted to each cassette.
- Specially designed electronic touch control panel allowing power, time and temperature control.
- Twin 30 minute programmable timers on both the Flash and Bake settings.
- Temperature settable on both Flash and Bake Cycle.
- Digital distance readout with safety cut out if unit is moved to close.
- Robust steel constructed stable frame, fitted with rear wheel locking castors.
- Maintenance free cassettes with no fan or filter changes.
- Individually switched cassettes.
- Horizontal or vertical cassette operation.
- When operating unit can display temperature or time remaining on Flash or Bake cycle.
- Long lamp/emitter life with an average of 6000hours. Typically 4 – 5 years continuous professional use.

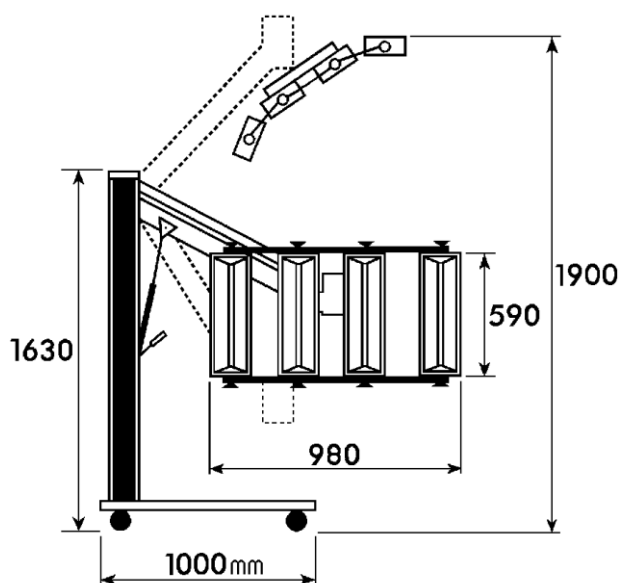

**Area coverage:- 800mm x 1300mm**  
Minimum operating distance:- 500mm  
Max vertical curing height:- 2030mm  
Max horizontal curing height:- 1800mm  
Max curing temperature:- 80°C

## Average curing specification

Filler / Stopper:- 4 – 6 minutes  
Primer:- 6 – 8 minutes  
Top coat:- 10 – 12 minutes

## Electrical specification

220/240 Volt 4KW 50Hz single phase 17amps

## La Grand E.V.O

Opzoomerstraat 21 b  
3023 SE Rotterdam  
tel. 010-2449966  
lagrand-evo@planet.nl  
www.lagrand-evo.nl



Distributed by