

HLP6000

The 6000 model has six 1 KW Glare Control lamps, fitted into three twin cassettes.

Lamps emit short wave infrared heat ideal for optimizing drying of waterborne paints.

This flexible system allows each cassette to be adjusted and locked into position around the contours of the vehicle body, ensuring maximum area coverage.

Height adjustment is made using the high performance locking gas strut, offering a near weightless movement to the cassette support arm.

Typical drying cycle only costs 18 Pence (Based on 1Kw/hour of electricity costing 12 pence).



Product features include

- 500mm 1Kw High output GC short wave tubes fitted to each cassette.
- Long lamp/emitter life with an average of 6000hours. Typically 4 – 5 years continuous professional use.
- Specially designed electronic power and time control, offering 0 - 100% heat instantly through twin 30 minute timers on both the Flash and Bake settings.
- Robust steel constructed stable frame, fitted with rear wheel locking castors.
- Maintenance free cassettes with no fan or filter changes.
- Easy height adjustments by locking gas strut.
- Individually switched cassettes.
- Horizontal or vertical cassette operation.

Area coverage:- 2000mm x 1000mm

Minimum operating distance:- 600mm

Max vertical curing height:- 2350mm

Max horizontal curing height:- 1800mm

Average curing specification

Filler / Stopper:- 4 – 6 minutes

Primer:- 6 – 8 minutes

Top coat:- 10 – 12 minutes

Electrical specification

220/240 Volt 6KW 50Hz single phase 25.00amps

380/415 Volt 6KW 50Hz 3 phase 8.33amps / phase

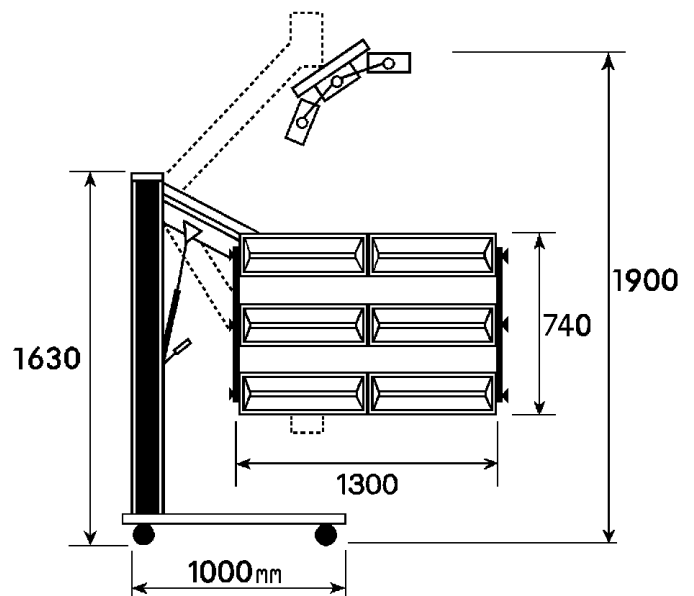

La Grand E.V.O

Opzoomerstraat 21 b
3023 SE Rotterdam
tel. 010-2449966
lagrand-evo@planet.nl
www.lagrand-evo.nl



Distributed by