

# HLP6000DS



The 6000 model has six 1 KW Glare Control lamps, fitted into three twin cassettes.

Unit is equipped with an ultrasonic distance indicator allowing it to be correctly positioned.

Lamps emit short wave infrared heat ideal for optimizing drying of waterborne paints.

This flexible system allows each cassette to be adjusted and locked into position around the contours of the vehicle body, ensuring maximum area coverage.

Height adjustment is made using the high performance locking gas strut, offering a near weightless movement to the cassette support arm.

Typical drying cycle only costs 18 Pence (Based on 1Kw/hour of electricity costing 12 pence)

## Product features include

- 500mm 1Kw High output GC short wave lamps fitted to each cassette.
- Twin 30 minute timers on both the Flash and Bake settings.
- Power settable on both Flash and Bake Cycle.
- Distance indicator with safety cut out if unit is moved too close.
- Robust steel constructed stable frame, fitted with rear wheel locking castors.
- Maintenance free cassettes with no fan or filter changes.
- Individually switched cassettes.
- Horizontal or vertical cassette operation.
- Long lamp/emitter life with an average of 6000hours. Typically 4 – 5 years continuous professional use.

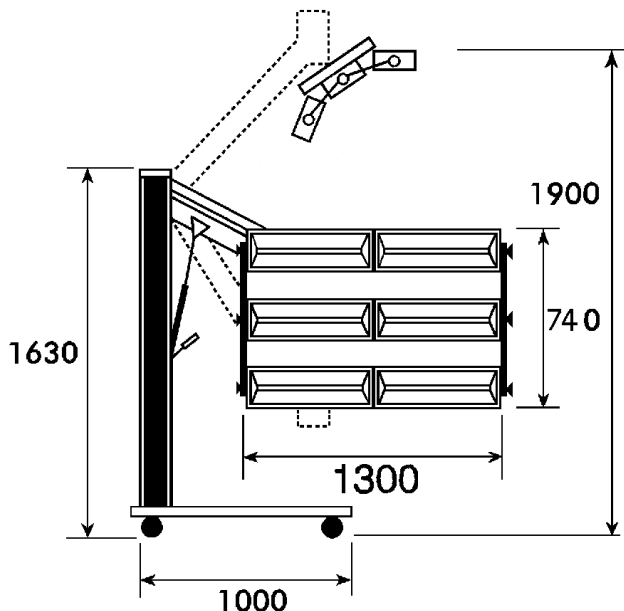

**Area coverage:-** 2000mm x 1000mm  
**Minimum operating distance:-** 600mm  
**Max vertical curing height:-** 2030mm  
**Max horizontal curing height:-** 1800mm

## Average curing specification

**Filler / Stopper:-** 4 – 6 minutes  
**Primer:-** 6 – 8 minutes  
**Top coat:-** 10 – 12 minutes

## Electrical specification

220/240 Volt 6KW 50Hz single phase 25.00amps  
380/415 Volt 6KW 50Hz 3 phase 8.33amps / phase

## La Grand E.V.O

Opzoomerstraat 21 b  
3023 SE Rotterdam  
tel. 010-2449966  
lagrand-evo@planet.nl  
www.lagrand-evo.nl



Distributed by